

CUEMASTER II

Theatre/TV Lighting Console



288 Channels, softpatch to 1024 Dimmers
Simple, fast, easy to operate control desk
Ideal for Theatre and TV Studio lighting

Theatrelight Ltd
Auckland, New Zealand
email: info@theatrelight.co.nz
web: www.theatrelight.co.nz

THEATRELIGHTNZ

THE NEW THEATRELIGHT CUEMASTER II

The new Cuemaster II adds to the original range of Cuemasters, popular for their reliability, simplicity, and ease of use. The new panel extends the channel capacity from 120 in the original Cuemaster up to 288 channels, and adds a proportional patch to 1024 dimmers. The new design keeps the simple operation of the original, making it one of the fastest control panels to use when getting a show on stage. The Cuemaster II is the ideal lighting control panel for small to medium theatres, for control of stadium lighting, and for TV Studio lighting.

FEATURES

- 288 Channel control with proportional soft-patch to 1024 dimmers
- 72 preset faders may be Channels or Scenes in blocks of 24 faders
- Multiple Scenemaster pages, with automatic page overlay memory
- Independent auto-loading fade times for Show Cues
- Any Show cue can link up to 20 Chases or Fade-Scenes
- Chases are level sensitive, and may be of any length
- Multiple independent Chase speeds - up to 20 simultaneously
- Chase Beat function for synchronizing chase speed to live music
- External control of auto-fade auto-effect Shows
- Fast editing of levels, fade times, and chase speeds
- Simple insertion or deletion of Chase steps or Show cues
- LCD display provides live monitoring of desk and on-screen Help
- Memory Card for memory expansion, back-up or library purposes

PANEL LEGEND

- A: The 72 preset faders and their flash keys can act as Channel faders, or as Scenemasters
 B: Each fader of the bottom row of Scenemasters can store a scene, a chase, or a complete auto-fade show
 C: Master faders for control of Channel levels, Park store levels, and Scenemaster playback levels
 D: Scene Fade master controls fade times from instant to 60 minutes, with a Hold Fade function
 E: Speed Master controls Chase playback speed. The Cue Go key plays back Show cues with recorded fade times
 F: Grand Master fader and DBO (Dead Black Out) key
 G: Page up and down keys allow access to 4 pages of Scenemasters. Up and Down Edit keys allow easy editing of all 288 channels levels. Other keys include Kill (Solo), Chase Reverse, Cue Back, and Preview

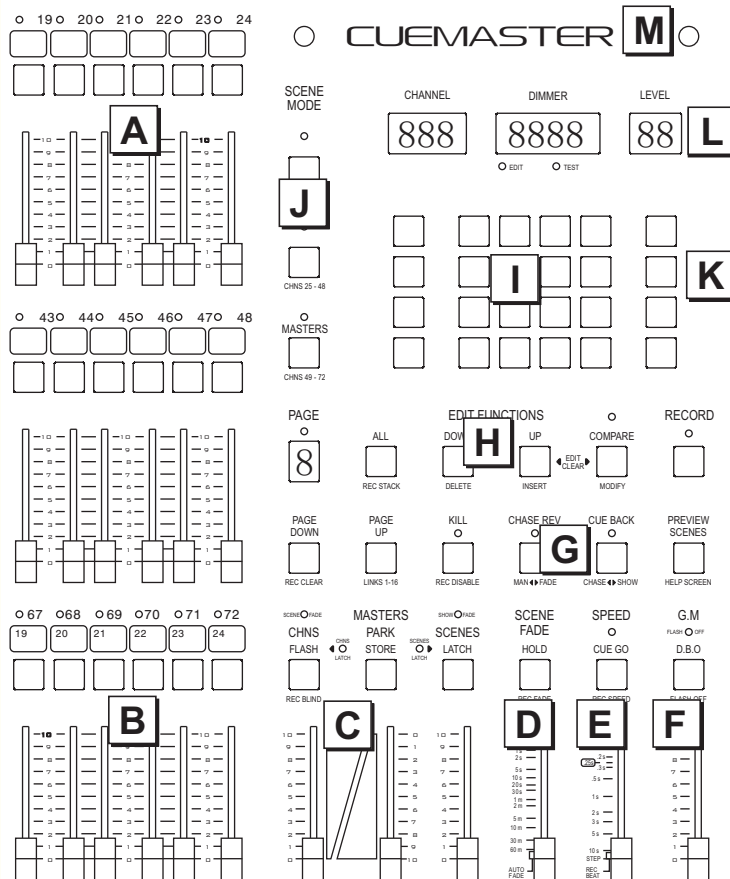

- H: Up, Down, and All keys allow easy setting or editing of all 288 channel levels. Compare key swaps edited levels and normal playback levels for fast comparison
 I: Soft patch keyboard patches any of the 1024 output dimmer channels to any of the 288 channels at any level. Channel and Dimmer Test functions are included
 J: Preset Fader Mode buttons switch each row of 24 preset faders between acting as Channel faders or acting as Scenemasters.
 K: Channel Page buttons enable Up/Down key editing of all 288 channel levels as 4 pages of 72 channels per page. All channel edits are displayed on LCD monitor
 L: Patch Display section shows Channel and Dimmer numbers and levels, and all Test function readouts
 M: Sockets for gooseneck work lights

Specifications

- Construction:** Zinc coated steel, powder coated epoxy paint
Faders: 60mm stroke linear faders with custom moulded ABS knobs. All faders are protected by a built in dust shield
Flash Keys: Long-life computer key switches with custom moulded ABS caps
Power Supply: Built-in transformer, switchable 110-120v / 220-240v
DMX Outputs: Two 5 pin XLR connectors
Remote Cue Trigger: 6.3mm stereo jack socket.

ACCESSORIES

- Monitors:** A range of LCD colour monitors is available
Desk Lights: Gooseneck lights to suit the BNC sockets are available
Memory Cards: Write-protectable memory card

Dimensions

Net weight 17Kg

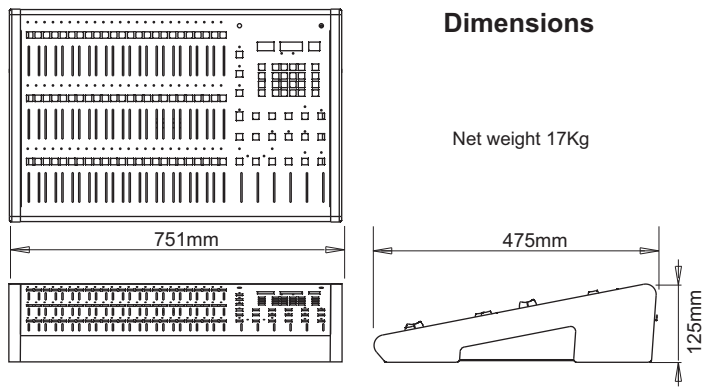

Your Local Distributor:

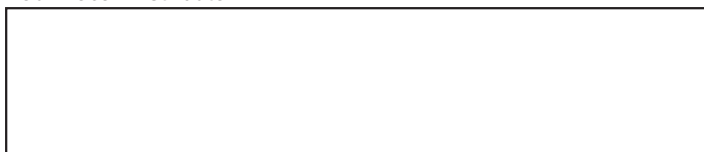

Theatrelight Ltd, 6 Rowe St. Onehunga, Auckland, New Zealand
 Tel: 64-9-622 1187, Fax: 64-9-636 5803
 internet: www.theatrelight.co.nz, email: info@theatrelight.co.nz